



SG290P

RESIDENTIAL LINE



Peimar polycrystalline solar panels made in Italy provide customers with a perfect combination of high-efficiency and versatility. Thanks to the use of high-quality solar cells, our panels achieve outstanding performance and ensure maximum production output even under poor lighting and weather conditions. The strong yet ultra-light frames, available in silver or black make installation easy but robust in either residential, commercial or large-scale settings.



30 YEAR LINEAR POWER WARRANTY

20 YEAR PRODUCT WARRANTY



MODULE FIRE PERFORMANCE: **CLASS 1**



ANTI-REFLECTIVE GLASS



QBE INSURANCE
Product Liability Insurance QBE

CELLS

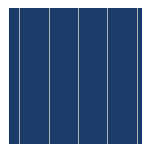

60 CELLS
POLY 5BB

156.75x156.75 mm / 6.17x6.17"

FRAME



COMPACT AND STURDY | **40mm**

ANCHORABLE ALSO ON THE SHORT SIDE ⁽⁴⁾

ELECTRICAL CHARACTERISTICS (STC) ⁽¹⁾

Nominal Output (Pmax)	
Power Tolerance	
Voltage at Pmax (Vmp)	
Current at Pmax (Imp)	
Open Circuit Voltage (Voc)	
Short Circuit Current (Isc)	
Maximum System Voltage	
Maximum Series Fuse Rating	
Module Efficiency	
Protection class against electric shock	

SG290P	
Nominal Output (Pmax)	290 W
Power Tolerance	0/+5 W
Voltage at Pmax (Vmp)	32.2 V
Current at Pmax (Imp)	9.01 A
Open Circuit Voltage (Voc)	39.28 V
Short Circuit Current (Isc)	9.64 A
Maximum System Voltage	1500 V
Maximum Series Fuse Rating	15 A
Module Efficiency	17.83%
Protection class against electric shock	Class II

MECHANICAL CHARACTERISTICS

Solar Cells	60 (6x10) polycrystalline
Solar Cells Size	156.75x156.75 mm / 6.17x6.17"
Front Cover	3.2 mm / 0.13" thick, low iron tempered glass
Back Cover	TPT (Tedlar-PET-Tedlar)
Encapsulant	EVA (Ethylene vinyl acetate)
Frame	Anodized aluminium alloy, double wall
Frame finishing	Silver / Black
Backsheet finishing	White
Diodes	3 Bypass diodes serviceable
Junction Box	IP67 rated
Connector	MC4 or compatible connector
Cables Length	900 mm / 35.43"
Cables Section	4.0 mm ² / 0.006 in ²
Dimensions	1640x992x40 mm / 64.57x39.06x1.57"
Weight	18 Kg / 39.68 lbs
Max. Load ⁽⁴⁾	Certified to 5400 Pa

TEMPERATURE CHARACTERISTICS

NOCT ⁽²⁾	45±2 °C
Temperature Coefficient of Pmax	-0.39 %/°C
Temperature Coefficient of Voc	-0.28 %/°C
Temperature Coefficient of Isc	0.042 %/°C
Operating Temperature	-40 °C ~ +85°C

PACKAGING ⁽³⁾

Pallet dimensions	1700x1200x1200 mm / 66.93x47.24x47.24"
Pieces per pallet	27
Weight	516 Kg / 1138 lbs

CERTIFICATIONS

Fire Resistance Rating	Class of reaction to fire 1 (UNI 9177)
------------------------	--

DIMENSIONS

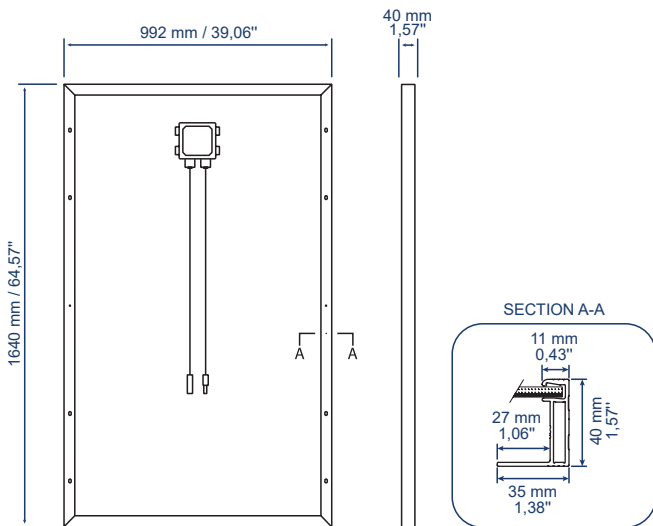

CURRENT/VOLTAGE CHARACTERISTICS

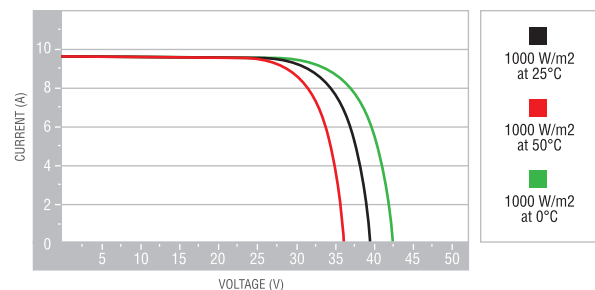
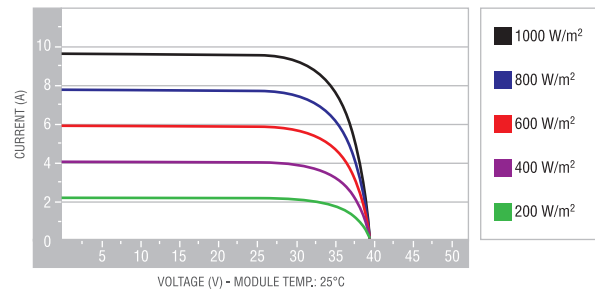

1. STC: (Standard Test Condition) Irradiance 1000W/m²; Module Temperature 25°C; Air Mass 1.5

2. NOCT: (Nominal Operation Cell Temperature) Irradiance 800W/m²; Air 20°C; Wind speed 1m/s

3. Pallets can be stacked up to two

4. Consult the installation manual for the relative mounting configurations